

## Q1.

- 3 An aluminium sheet is suspended from an oscillator by means of a spring, as illustrated in Fig. 3.1.

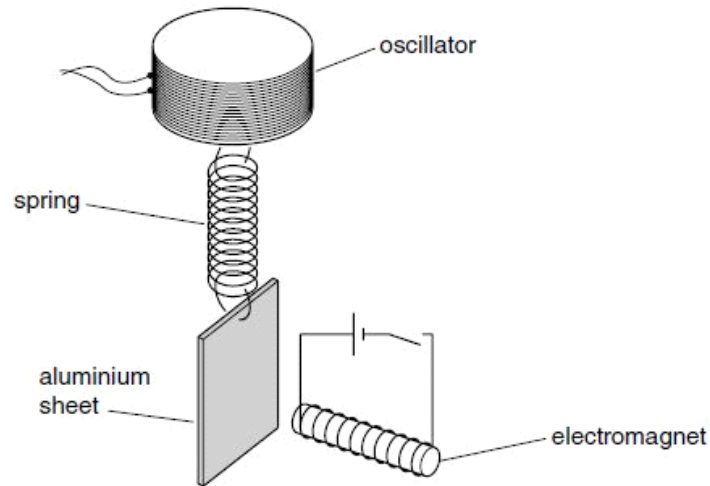

Fig. 3.1

An electromagnet is placed a short distance from the centre of the aluminium sheet.

The electromagnet is switched off and the frequency  $f$  of oscillation of the oscillator is gradually increased from a low value. The variation with frequency  $f$  of the amplitude  $a$  of vibration of the sheet is shown in Fig. 3.2.

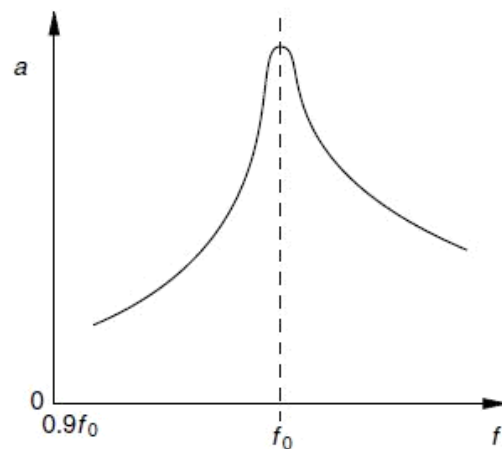

Fig. 3.2

A peak on the graph appears at frequency  $f_0$ .

(a) Explain why there is a peak at frequency  $f_0$ .

.....  
.....  
..... [2]

(b) The electromagnet is now switched on and the frequency of the oscillator is again gradually increased from a low value. On Fig. 3.2, draw a line to show the variation with frequency  $f$  of the amplitude  $a$  of vibration of the sheet. [3]

(c) The frequency of the oscillator is now maintained at a constant value. The amplitude of vibration is found to decrease when the current in the electromagnet is switched on.

Use the laws of electromagnetic induction to explain this observation.

.....  
.....  
.....  
.....  
.....  
..... [4]

**Q2.**

4 A vertical spring supports a mass, as shown in Fig. 4.1.

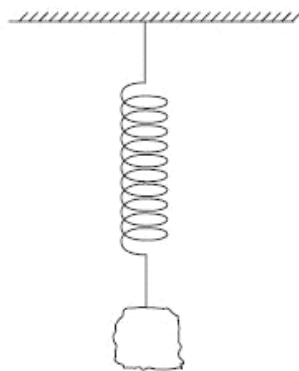

**Fig. 4.1**

The mass is displaced vertically then released. The variation with time  $t$  of the displacement  $y$  from its mean position is shown in Fig. 4.2.

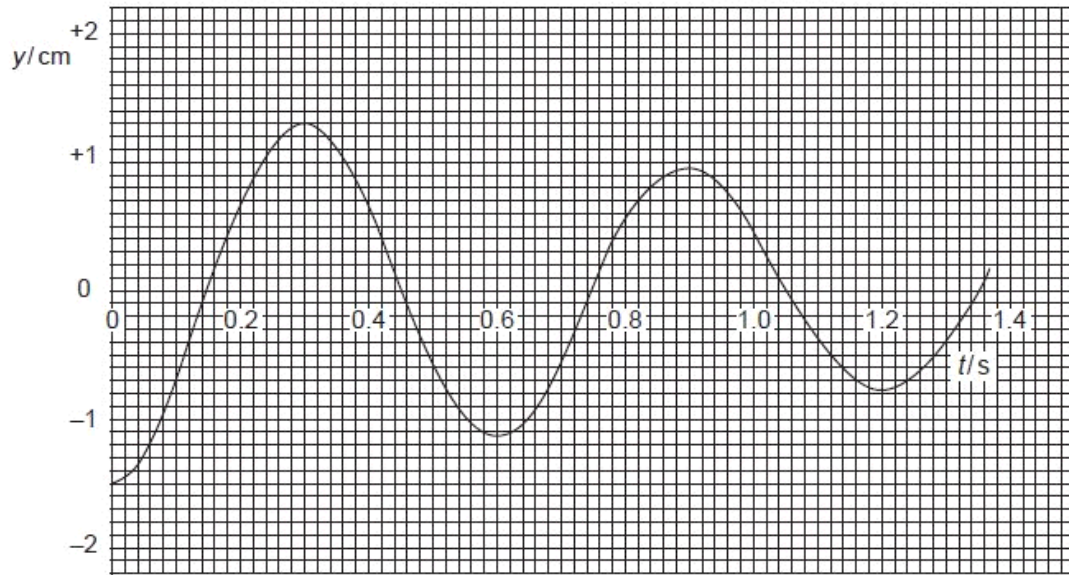

Fig. 4.2

A student claims that the motion of the mass may be represented by the equation

$$y = y_0 \sin \omega t.$$

(a) Give two reasons why the use of this equation is inappropriate.

1. ....  
 .....  
 2. ....  
 ..... [2]

(b) Determine the angular frequency  $\omega$  of the oscillations.

angular frequency = ..... rad s<sup>-1</sup> [2]

(c) The mass is a lump of plasticine. The plasticine is now flattened so that its surface area is increased. The mass of the lump remains constant and the large surface area is horizontal.  
 The plasticine is displaced downwards by 1.5 cm and then released.  
 On Fig. 4.2, sketch a graph to show the subsequent oscillations of the plasticine. [3]

**Q3.**

- 4 A tube, closed at one end, has a constant area of cross-section  $A$ . Some lead shot is placed in the tube so that the tube floats vertically in a liquid of density  $\rho$ , as shown in Fig. 4.1.

u

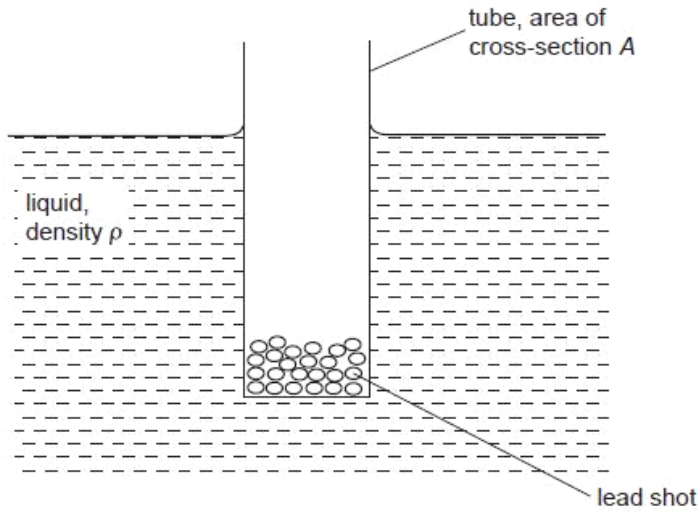

Fig. 4.1

The total mass of the tube and its contents is  $M$ .  
 When the tube is given a small vertical displacement and then released, the vertical acceleration  $a$  of the tube is related to its vertical displacement  $y$  by the expression

$$a = -\frac{A\rho g}{M} y,$$

where  $g$  is the acceleration of free fall.

- (a) Define *simple harmonic motion*.

.....  
 .....  
 .....[2]

- (b) Show that the tube is performing simple harmonic motion with a frequency  $f$  given by

$$f = \frac{1}{2\pi} \sqrt{\frac{A\rho g}{M}}.$$

[3]

- (c) Fig. 4.2 shows the variation with time  $t$  of the vertical displacement  $y$  of the tube in another liquid.

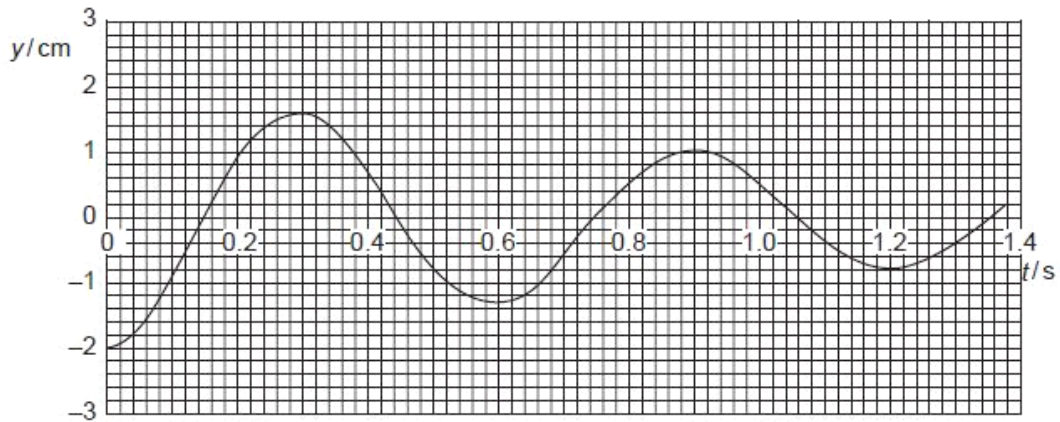

Fig. 4.2

- (i) The tube has an external diameter of 2.4 cm and is floating in a liquid of density  $950 \text{ kg m}^{-3}$ . Assuming the equation in (b), calculate the mass of the tube and its contents.

mass = ..... kg [3]

- (ii) State what feature of Fig. 4.2 indicates that the oscillations are damped.

.....  
 ..... [1]

Q4.

- 4 A piston moves vertically up and down in a cylinder, as illustrated in Fig. 4.1.

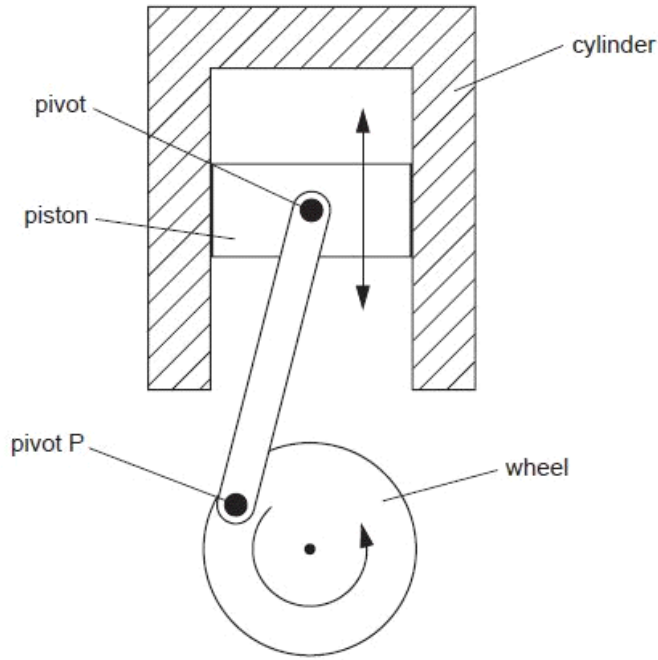

Fig. 4.1

The piston is connected to a wheel by means of a rod that is pivoted at the piston and at the wheel. As the piston moves up and down, the wheel is made to rotate.

- (a) (i) State the number of oscillations made by the piston during one complete rotation of the wheel.

number = ..... [1]

- (ii) The wheel makes 2400 revolutions per minute. Determine the frequency of oscillation of the piston.

frequency = ..... Hz [1]

(b) The amplitude of the oscillations of the piston is 42 mm.

Assuming that these oscillations are simple harmonic, calculate the maximum values for the piston of

(i) the linear speed,

speed = .....  $\text{m s}^{-1}$  [2]

(ii) the acceleration.

acceleration = .....  $\text{m s}^{-2}$  [2]

(c) On Fig. 4.1, mark a position of the pivot P for the piston to have

(i) maximum speed (mark this position S), [1]

(ii) maximum acceleration (mark this position A). [1]

**Q5.**



- 7 A magnet is suspended vertically from a fixed point by means of a spring, as shown in Fig. 7.1.

Use

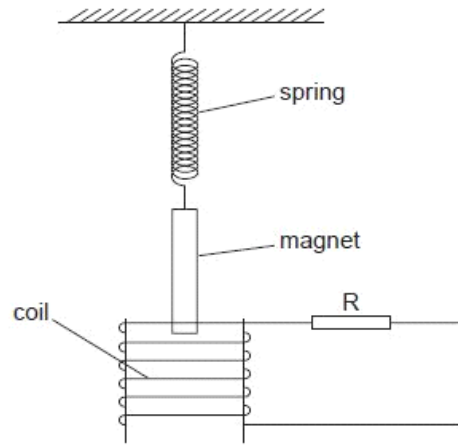

Fig. 7.1

One end of the magnet hangs inside a coil of wire. The coil is connected in series with a resistor  $R$ .

- (a) The magnet is displaced vertically a small distance  $D$  and then released. Fig. 7.2 shows the variation with time  $t$  of the vertical displacement  $d$  of the magnet from its equilibrium position.

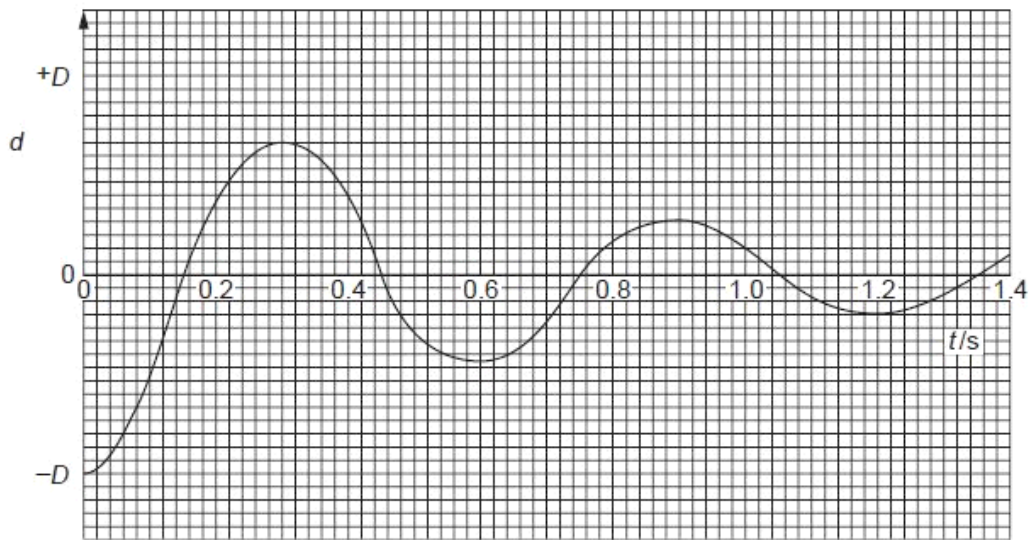

Fig. 7.2

(i) State and explain, by reference to electromagnetic induction, the nature of the oscillations of the magnet.

.....

.....

.....

.....

.....

.....

..... [5]

(ii) Calculate the angular frequency  $\omega_0$  of the oscillations.

$\omega_0 = \dots\dots\dots \text{ rad s}^{-1}$  [2]

(b) The resistance of the resistor R is increased.  
 The magnet is again displaced a vertical distance  $D$  and released.  
 On Fig. 7.2, sketch the variation with time  $t$  of the displacement  $d$  of the magnet. [2]

- (c) The resistor R in Fig. 7.1 is replaced by a variable-frequency signal generator of constant r.m.s. output voltage. The angular frequency  $\omega$  of the generator is gradually increased from about  $0.7\omega_0$  to about  $1.3\omega_0$ , where  $\omega_0$  is the angular frequency calculated in (a)(ii).

- (i) On the axes of Fig. 7.3, sketch a graph to show the variation with  $\omega$  of the amplitude A of the oscillations of the magnet. [2]

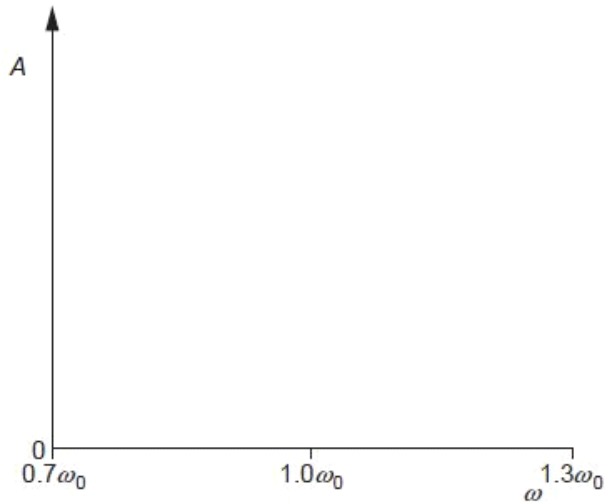

Fig. 7.3

- (ii) State the name of the phenomenon illustrated in the graph of Fig. 7.3.

..... [1]

- (iii) Briefly describe one situation where the phenomenon named in (ii) is useful and one situation where it should be avoided.

useful: .....

.....

avoid: .....

..... [2]

Q6.

- 3 A tube, closed at one end, has a uniform area of cross-section. The tube contains some sand so that the tube floats upright in a liquid, as shown in Fig. 3.1.

Exar  
L

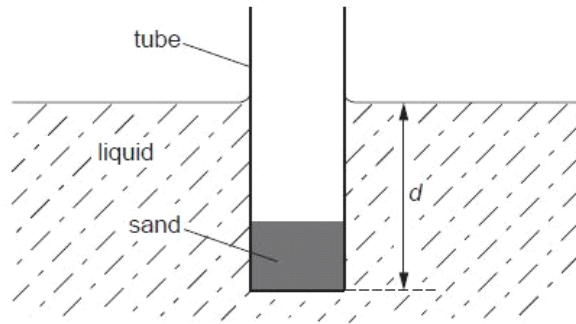

Fig. 3.1

When the tube is at rest, the depth  $d$  of immersion of the base of the tube is 16 cm. The tube is displaced vertically and then released.

The variation with time  $t$  of the depth  $d$  of the base of the tube is shown in Fig. 3.2.

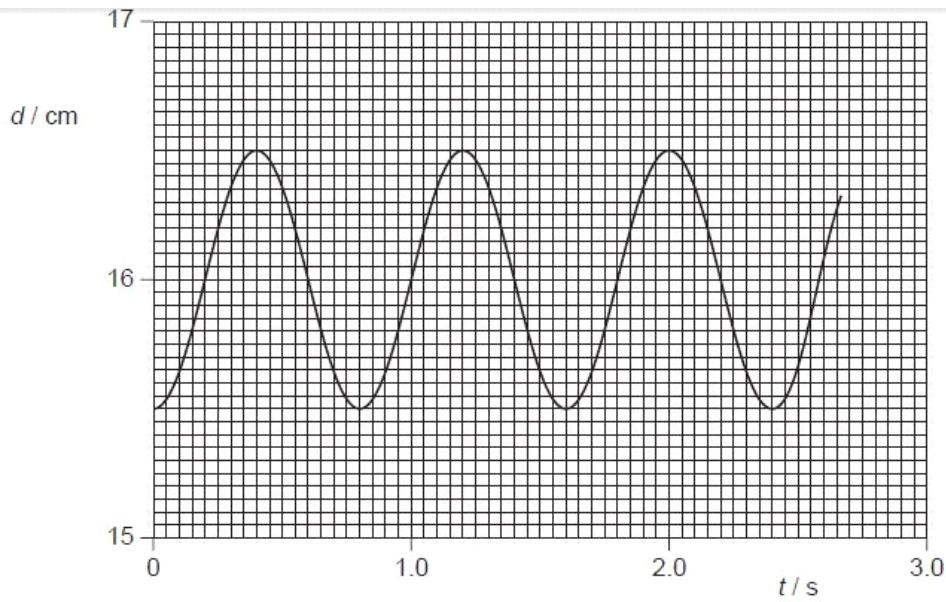

Fig. 3.2

- (a) Use Fig. 3.2 to determine, for the oscillations of the tube,

- (i) the amplitude,

amplitude = ..... cm [1]

- (ii) the period.

period = ..... s [1]

(b) (i) Calculate the vertical speed of the tube at a point where the depth  $d$  is 16.2 cm.

F  
Exam  
U

speed = ..... cm s<sup>-1</sup> [3]

(ii) State **one** other depth  $d$  where the speed will be equal to that calculated in (i).

$d$  = ..... cm [1]

(c) (i) Explain what is meant by *damping*.

.....  
.....  
.....  
..... [2]

(ii) The liquid in (b) is now cooled so that, although the density is unchanged, there is friction between the liquid and the tube as it oscillates. Having been displaced, the tube completes approximately 10 oscillations before coming to rest. On Fig. 3.2, draw a line to show the variation with time  $t$  of depth  $d$  for the first 2.5 s of the motion. [3]

Q7.

3 (a) State what is meant by

(i) *oscillations*,

.....  
..... [1]

(ii) *free oscillations*,

.....  
..... [1]

(iii) *simple harmonic motion*.

.....  
.....  
..... [2]

(b) Two inclined planes RA and LA each have the same constant gradient. They meet at their lower edges, as shown in Fig. 3.1.

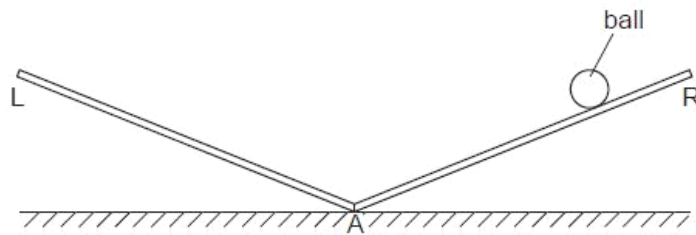

Fig. 3.1

A small ball moves from rest down plane RA and then rises up plane LA. It then moves down plane LA and rises up plane RA to its original height. The motion repeats itself.

State and explain whether the motion of the ball is simple harmonic.

.....  
.....  
..... [2]

Q8.

- 2 A long strip of springy steel is clamped at one end so that the strip is vertical. A mass of 65 g is attached to the free end of the strip, as shown in Fig. 2.1.

For  
Examine  
Use

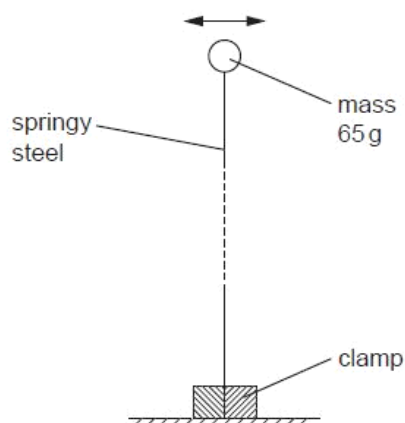

Fig. 2.1

The mass is pulled to one side and then released. The variation with time  $t$  of the horizontal displacement of the mass is shown in Fig. 2.2.

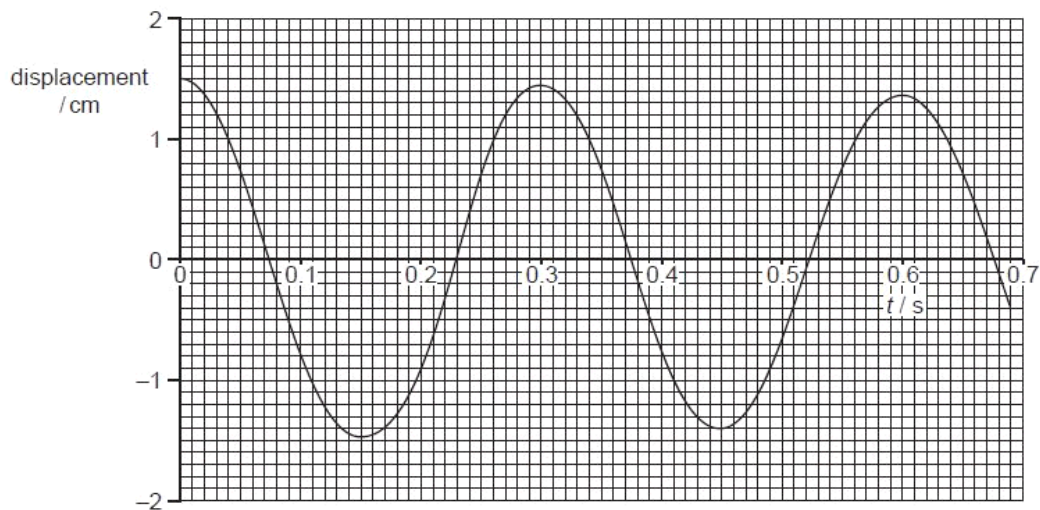

Fig. 2.2

The mass undergoes damped simple harmonic motion.

- (a) (i) Explain what is meant by *damping*.

.....  
.....  
..... [2]

(ii) Suggest, with a reason, whether the damping is light, critical or heavy.

.....  
.....  
..... [2]

For  
Examiner's  
Use

(b) (i) Use Fig. 2.2 to determine the frequency of vibration of the mass.

frequency = ..... Hz [1]

(ii) Hence show that the initial energy stored in the steel strip before the mass is released is approximately 3.2 mJ.

[2]

(c) After eight complete oscillations of the mass, the amplitude of vibration is reduced from 1.5 cm to 1.1 cm. State and explain whether, after a further eight complete oscillations, the amplitude will be 0.7 cm.

.....  
.....  
..... [2]

**Q9.**



- 3 (a) Define *simple harmonic motion*.

Ex

.....  
.....  
.....[2]

- (b) A tube, sealed at one end, has a total mass  $m$  and a uniform area of cross-section  $A$ . The tube floats upright in a liquid of density  $\rho$  with length  $L$  submerged, as shown in Fig. 3.1a.

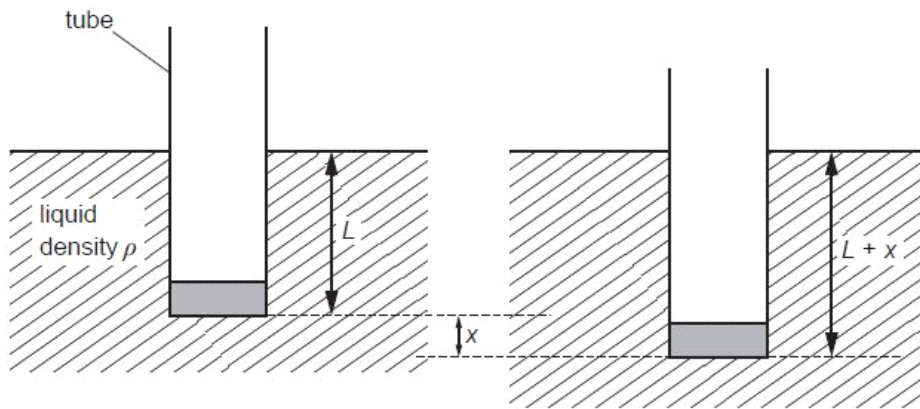

Fig. 3.1a

Fig. 3.1b

The tube is displaced vertically and then released. The tube oscillates vertically in the liquid.

At one time, the displacement is  $x$ , as shown in Fig. 3.1b.

Theory shows that the acceleration  $a$  of the tube is given by the expression

$$a = -\frac{A\rho g}{m}x.$$

- (i) Explain how it can be deduced from the expression that the tube is moving with simple harmonic motion.

For  
Examin  
Use

.....  
.....  
..... [2]

- (ii) The tube, of area of cross-section  $4.5\text{cm}^2$ , is floating in water of density  $1.0 \times 10^3\text{kg m}^{-3}$ .

Calculate the mass of the tube that would give rise to oscillations of frequency 1.5 Hz.

mass = ..... g [4]

### Q10.

- 4 A small metal ball is suspended from a fixed point by means of a string, as shown in Fig. 4.1.

For  
Examine  
Use

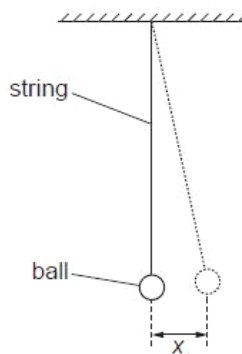
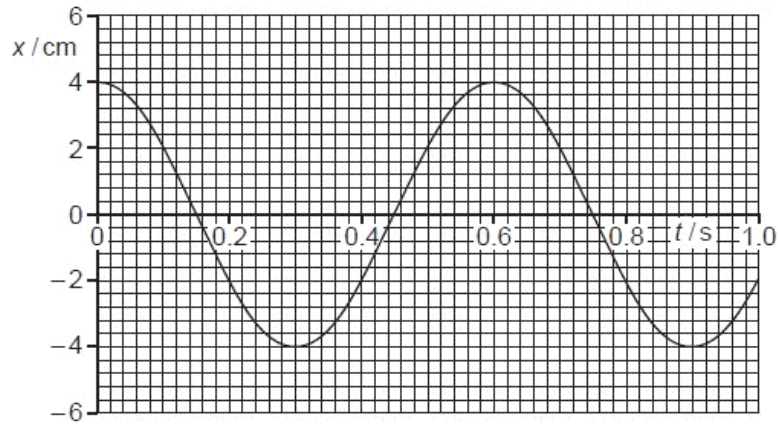

Fig. 4.1

The ball is pulled a small distance to one side and then released. The variation with time  $t$  of the horizontal displacement  $x$  of the ball is shown in Fig. 4.2.



**Fig. 4.2**

The motion of the ball is simple harmonic.

- (a)** Use data from Fig. 4.2 to determine the horizontal acceleration of the ball for a displacement  $x$  of 2.0 cm.

acceleration = .....  $\text{ms}^{-2}$  [3]

- (b) The maximum kinetic energy of the ball is  $E_K$ .  
On the axes of Fig. 4.3, sketch a graph to show the variation with time  $t$  of the kinetic energy of the ball for the first 1.0 s of its motion.

F  
Exam  
U

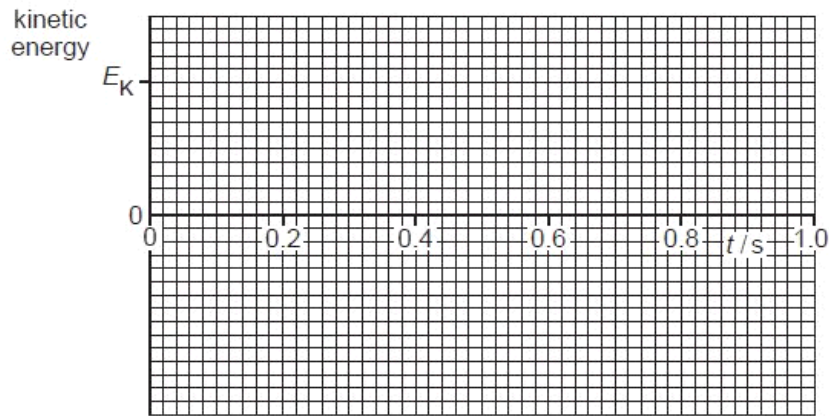

Fig. 4.3

[3]

**Q11.**

- 2 A ball of mass 37 g is held between two fixed points A and B by two stretched helical springs, as shown in Fig. 2.1.

F  
Exam  
U

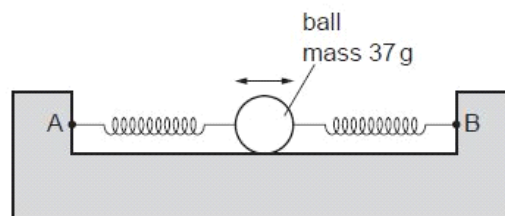

Fig. 2.1

The ball oscillates along the line AB with simple harmonic motion of frequency 3.5 Hz and amplitude 2.8 cm.

- (a) Show that the total energy of the oscillations is 7.0 mJ.

[2]

- (b) At two points in the oscillation of the ball, its kinetic energy is equal to the potential energy stored in the springs.  
Calculate the magnitude of the displacement at which this occurs.

displacement = ..... cm [3]

- (c) On the axes of Fig. 2.2 and using your answers in (a) and (b), sketch a graph to show the variation with displacement  $x$  of

- (i) the total energy of the system (label this line T), [1]  
(ii) the kinetic energy of the ball (label this line K), [2]  
(iii) the potential energy stored in the springs (label this line P). [2]

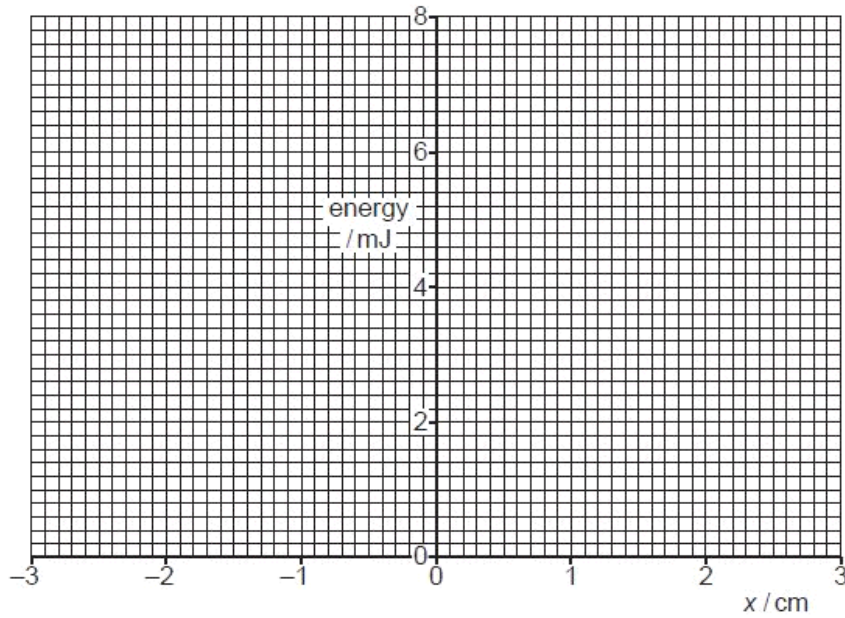

Fig. 2.2

- (d) The arrangement in Fig. 2.1 is now rotated through  $90^\circ$  so that the line AB is vertical and the ball oscillates in a vertical plane.

Suggest one form of energy, other than those in (c), that must be taken into consideration when plotting new graphs to show energy changes with displacement.

.....[1]

## Q12.

- 3 A ball is held between two fixed points A and B by means of two stretched springs, as shown in Fig. 3.1.

For  
Examine  
Use

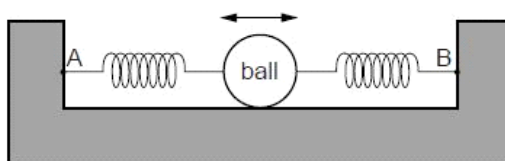

Fig. 3.1

The ball is free to oscillate along the straight line AB. The springs remain stretched and the motion of the ball is simple harmonic.

The variation with time  $t$  of the displacement  $x$  of the ball from its equilibrium position is shown in Fig. 3.2.

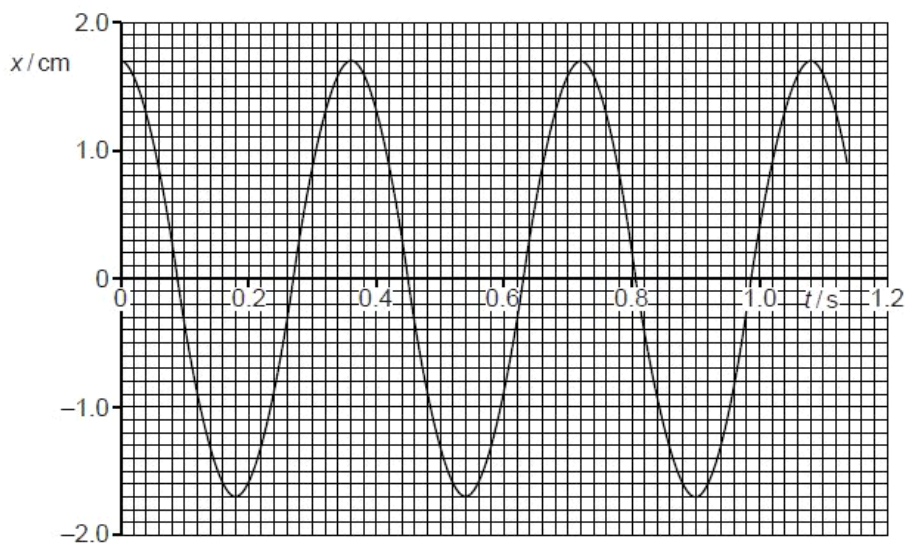

Fig. 3.2

(a) (i) Use Fig. 3.2 to determine, for the oscillations of the ball,

1. the amplitude,

amplitude = ..... cm [1]

2. the frequency.

frequency = ..... Hz [2]

(ii) Show that the maximum acceleration of the ball is  $5.2 \text{ m s}^{-2}$ .

E

[2]

(b) Use your answers in (a) to plot, on the axes of Fig. 3.3, the variation with displacement  $x$  of the acceleration  $a$  of the ball.

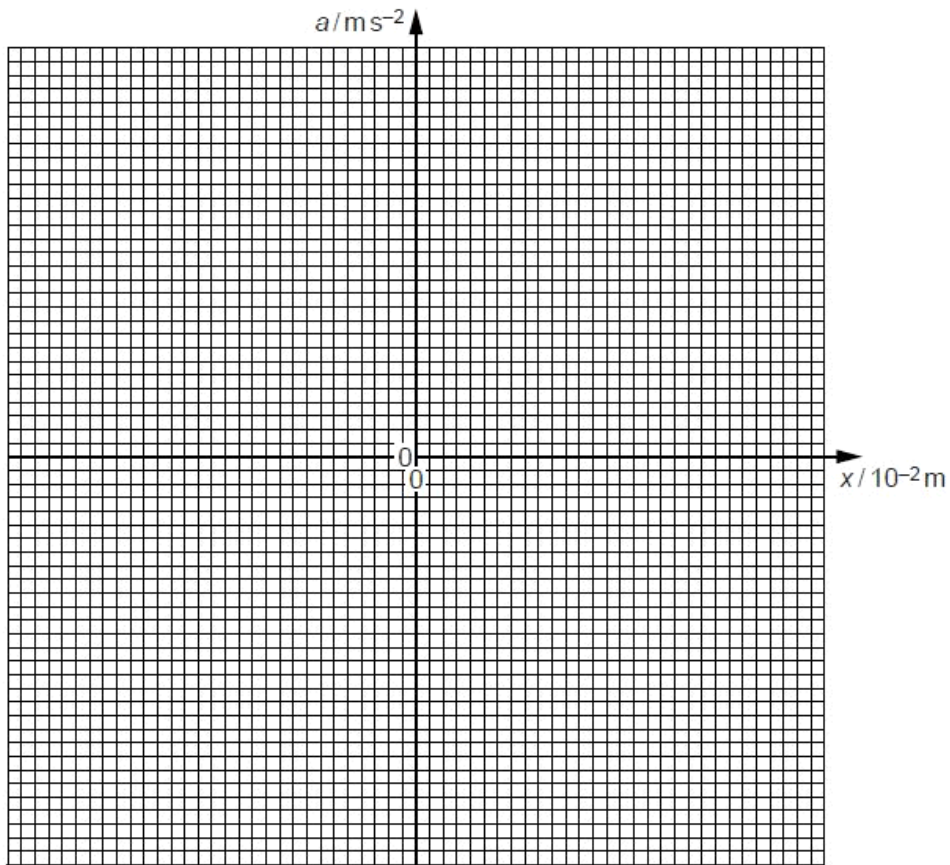

Fig. 3.3

[2]

- (c) Calculate the displacement of the ball at which its kinetic energy is equal to one half of the maximum kinetic energy.

For  
Examin  
Use

displacement = ..... cm [3]

Q13.



- 3 A mass of 78 g is suspended from a fixed point by means of a spring, as illustrated in Fig. 3.1.

For  
Examiner's  
Use

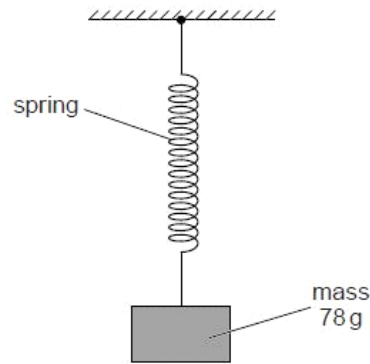

Fig. 3.1

The stationary mass is pulled vertically downwards through a distance of 2.1 cm and then released.

The mass is observed to perform simple harmonic motion with a period of 0.69 s.

- (a) The mass is released at time  $t = 0$ .

For the oscillations of the mass,

- (i) calculate the angular frequency  $\omega$ ,

$$\omega = \dots\dots\dots \text{rad s}^{-1} \quad [2]$$

- (ii) determine numerical equations for the variation with time  $t$  of

1. the displacement  $x$  in cm,

.....  
 ..... [2]

2. the speed  $v$  in  $\text{m s}^{-1}$ .

.....  
 ..... [2]

(b) Calculate the total energy of oscillation of the mass.

For  
Examiner  
Use

energy = ..... J [2]

**Q14.**

3 A student sets out to investigate the oscillation of a mass suspended from the free end of a spring, as illustrated in Fig. 3.1.

Use

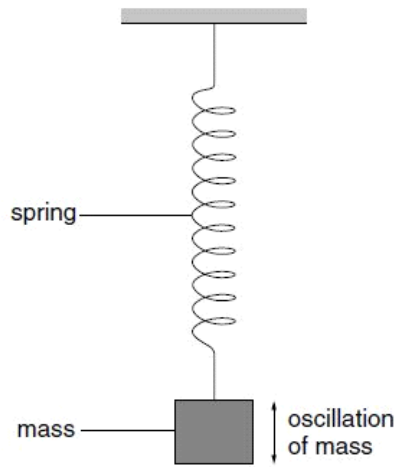

**Fig. 3.1**

The mass is pulled downwards and then released. The variation with time  $t$  of the displacement  $y$  of the mass is shown in Fig. 3.2.

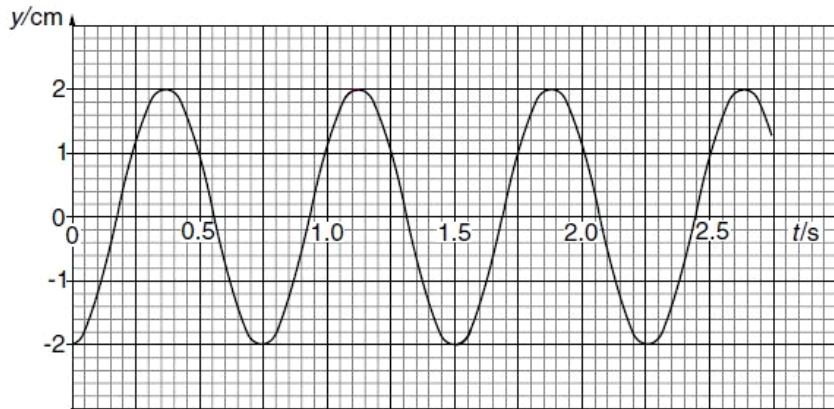

Fig. 3.2

(a) Use information from Fig. 3.2

(i) to explain why the graph suggests that the oscillations are undamped,

.....

(ii) to calculate the angular frequency of the oscillations,

Use

angular frequency = .....  $\text{rad s}^{-1}$

(iii) to determine the maximum speed of the oscillating mass.

speed = .....  $\text{m s}^{-1}$   
[6]

- (b) (i) Determine the resonant frequency  $f_0$  of the mass-spring system.

$$f_0 = \dots\dots\dots \text{ Hz}$$

- (ii) The student finds that if short impulsive forces of frequency  $\frac{1}{2}f_0$  are impressed on the mass-spring system, a large amplitude of oscillation is obtained. Explain this observation.

.....

.....

.....

[3]

**Q15.**

- 2 (a) The defining equation of simple harmonic motion is

$$a = -\omega^2 x.$$

- (i) Identify the symbols in the equation.

$a$  .....

$\omega$  .....

$x$  .....

- (ii) State the significance of the negative (-) sign in the equation.

.....

.....

[3]

- (b) A frictionless trolley of mass  $m$  is held on a horizontal surface by means of two similar springs, each of spring constant  $k$ . The springs are attached to fixed points as illustrated in Fig. 2.1.

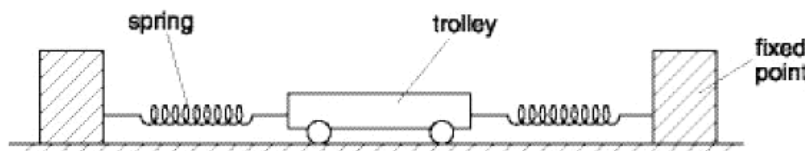

Fig. 2.1

When the trolley is in equilibrium, the extension of each spring is  $e$ .

The trolley is then displaced a small distance  $x$  to the right along the axis of the springs. Both springs remain extended.

- (i) Show that the magnitude  $F$  of the restoring force acting on the trolley is given by

$$F = 2kx.$$

[2]

- (ii) The trolley is then released. Show that the acceleration  $a$  of the trolley is given by

$$a = \frac{-2kx}{m}.$$

[2]

Us

(iii) The mass  $m$  of the trolley is 900g and the spring constant  $k$  is  $120 \text{ N m}^{-1}$ . By comparing your answer to (a)(i) and the equation in (b)(ii), determine the frequency of oscillation of the trolley.

frequency = ..... Hz [3]

(c) Suggest why the trolley in (b) provides a simple model for the motion of an atom in a crystal.

.....  
.....  
..... [2]

**Q16.**

- 3 The vibrations of a mass of 150 g are simple harmonic. Fig. 3.1 shows the variation with displacement  $x$  of the kinetic energy  $E_k$  of the mass.

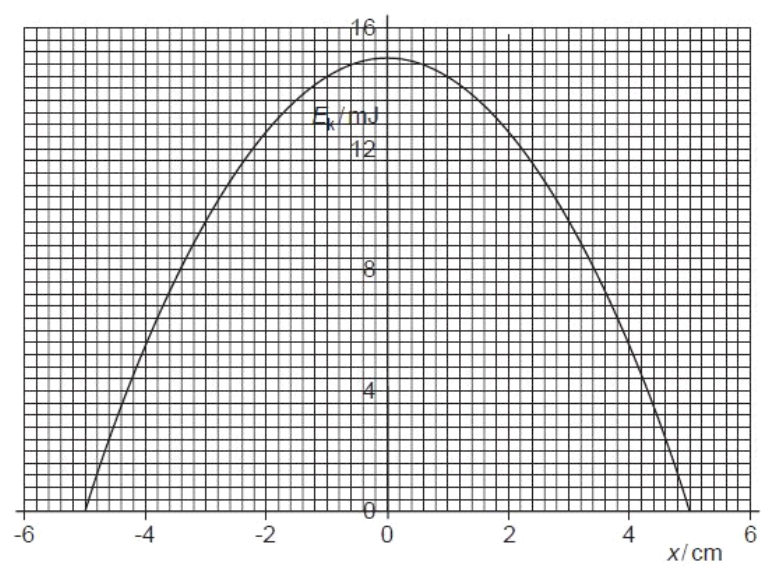

Fig. 3.1

- (a) On Fig. 3.1, draw lines to represent the variation with displacement  $x$  of
- (i) the potential energy of the vibrating mass (label this line P),
  - (ii) the total energy of the vibrations (label this line T).

[2]

- (b) Calculate the angular frequency of the vibrations of the mass.

angular frequency = ..... rad s<sup>-1</sup> [3]

(c) The oscillations are now subject to damping.

Use

(i) Explain what is meant by *damping*.

.....  
.....  
.....[2]

(ii) The mass loses 20% of its vibrational energy. Use Fig. 3.1 to determine the new amplitude of oscillation. Explain your working.

amplitude = ..... cm [2]

### Q17.

4 The centre of the cone of a loudspeaker is oscillating with simple harmonic motion of frequency 1400 Hz and amplitude 0.080 mm.

Use

(a) Calculate, to two significant figures,

(i) the angular frequency  $\omega$  of the oscillations,

$\omega = \dots\dots\dots \text{rad s}^{-1}$  [2]

(ii) the maximum acceleration, in  $\text{m s}^{-2}$ , of the centre of the cone.

acceleration = .....  $\text{m s}^{-2}$  [2]



- (b) On the axes of Fig. 4.1, sketch a graph to show the variation with displacement  $x$  of the acceleration  $a$  of the centre of the cone.

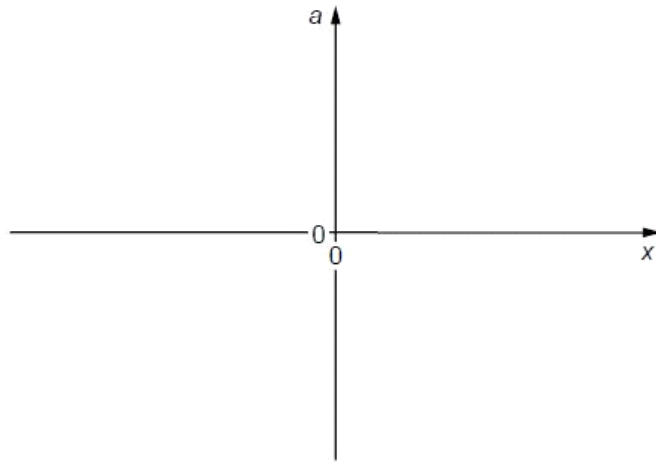

[2]

Fig. 4.1

- (c) (i) State the value of the displacement  $x$  at which the speed of the centre of the cone is a maximum.

$x = \dots\dots\dots$  mm [1]

- (ii) Calculate, in  $\text{m s}^{-1}$ , this maximum speed.

speed =  $\dots\dots\dots$   $\text{m s}^{-1}$  [2]

Q18.

- 3 Two vertical springs, each having spring constant  $k$ , support a mass. The lower spring is attached to an oscillator as shown in Fig. 3.1.

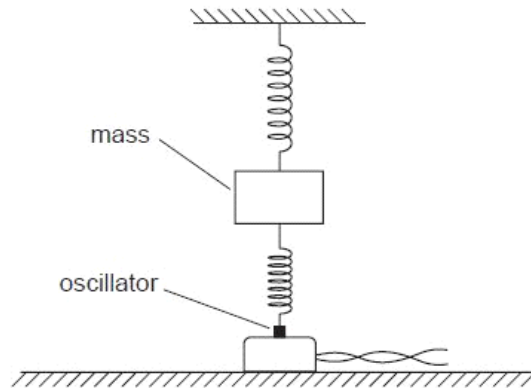

**Fig. 3.1**

The oscillator is switched off. The mass is displaced vertically and then released so that it vibrates. During these vibrations, the springs are always extended. The vertical acceleration  $a$  of the mass  $m$  is given by the expression

$$ma = -2kx,$$

where  $x$  is the vertical displacement of the mass from its equilibrium position.

- (a) Show that, for a mass of 240 g and springs with spring constant  $3.0 \text{ N cm}^{-1}$ , the frequency of vibration of the mass is approximately 8 Hz.

- (b) The oscillator is switched on and the frequency  $f$  of vibration is gradually increased. The amplitude of vibration of the oscillator is constant.

Fig. 3.2 shows the variation with  $f$  of the amplitude  $A$  of vibration of the mass.

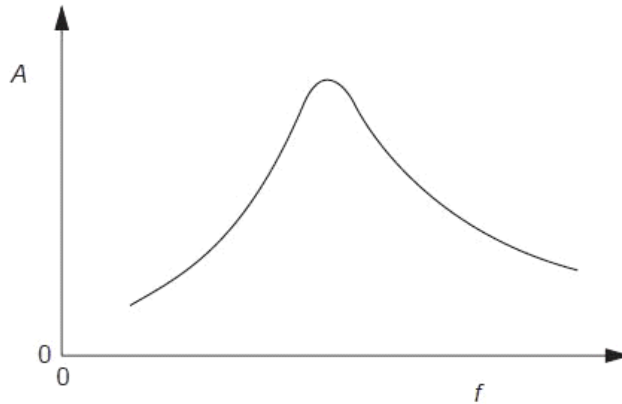

Fig. 3.2

State

- (i) the name of the phenomenon illustrated in Fig. 3.2,

..... [1]

- (ii) the frequency  $f_0$  at which maximum amplitude occurs.

frequency = ..... Hz [1]

- (c) Suggest and explain how the apparatus in Fig. 3.1 could be modified to make the peak on Fig. 3.2 flatter, without significantly changing the frequency  $f_0$  at which the peak occurs.

.....  
.....  
.....  
..... [3]

Q19.

- 3 A spring is hung from a fixed point. A mass of 130 g is hung from the free end of the spring, as shown in Fig. 3.1.

USE

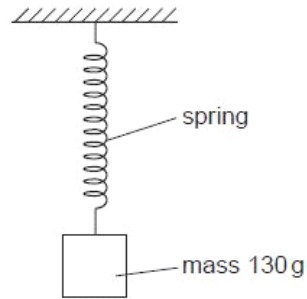

Fig. 3.1

The mass is pulled downwards from its equilibrium position through a small distance  $d$  and is released. The mass undergoes simple harmonic motion. Fig. 3.2 shows the variation with displacement  $x$  from the equilibrium position of the kinetic energy of the mass.

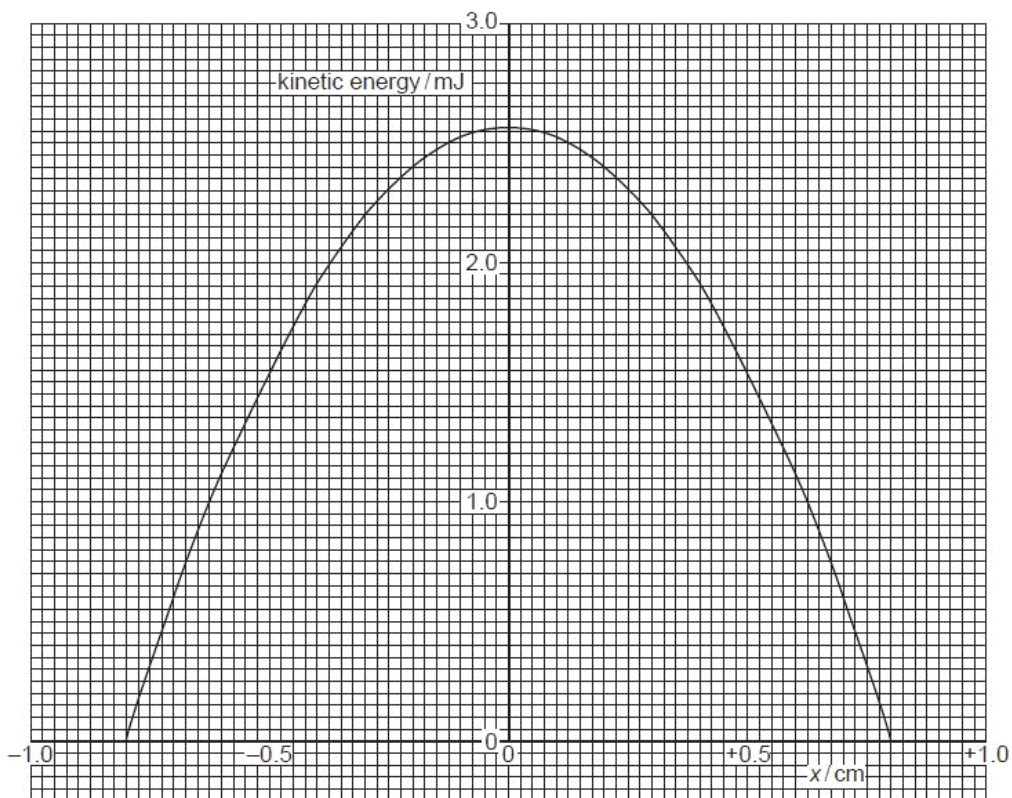

Fig. 3.2

(a) Use Fig. 3.2 to

(i) determine the distance  $d$  through which the mass was displaced initially,

$d = \dots\dots\dots$  cm [1]

(ii) show that the frequency of oscillation of the mass is approximately 4.0 Hz.

[6]

(b) (i) On Fig. 3.2, draw a line to represent the total energy of the oscillating mass. [1]

(ii) After many oscillations, damping reduces the total energy of the mass to 1.0 mJ. For the oscillations with reduced energy,

1. state the frequency,

frequency =  $\dots\dots\dots$  Hz

2. using the graph, or otherwise, state the amplitude.

amplitude =  $\dots\dots\dots$  cm [2]

**Q20.**

- 3 The needle of a sewing machine is made to oscillate vertically through a total distance of 22 mm, as shown in Fig. 3.1.

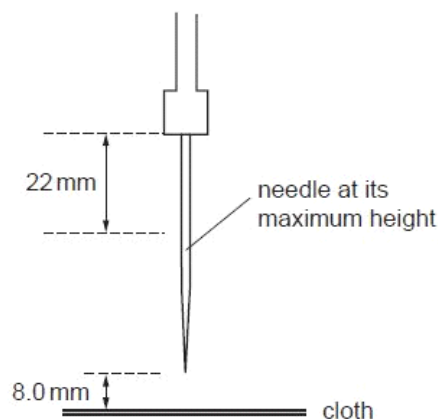

Fig. 3.1

The oscillations are simple harmonic with a frequency of 4.5 Hz.  
The cloth that is being sewn is positioned 8.0 mm below the point of the needle when the needle is at its maximum height.

- (a) State what is meant by *simple harmonic motion*.

.....  
 .....  
 ..... [2]

- (b) The displacement  $y$  of the point of the needle may be represented by the equation

$$y = a \cos \omega t.$$

- (i) Suggest the position of the point of the needle at time  $t = 0$ .

..... [1]

- (ii) Determine the values of

1.  $a$ ,

$a =$  ..... mm [1]

2.  $\omega$ .

$\omega =$  .....  $\text{rads}^{-1}$  [2]

(c) Calculate, for the point of the needle,

(i) its maximum speed,

For  
Examiner's  
Use

speed = .....  $\text{ms}^{-1}$  [2]

(ii) its speed as it moves downwards through the cloth.

speed = .....  $\text{ms}^{-1}$  [3]

**Q21.**

- 4 The variation with time  $t$  of the displacement  $x$  of the cone of a loudspeaker is shown in Fig. 4.1.

For  
Examiner  
Use

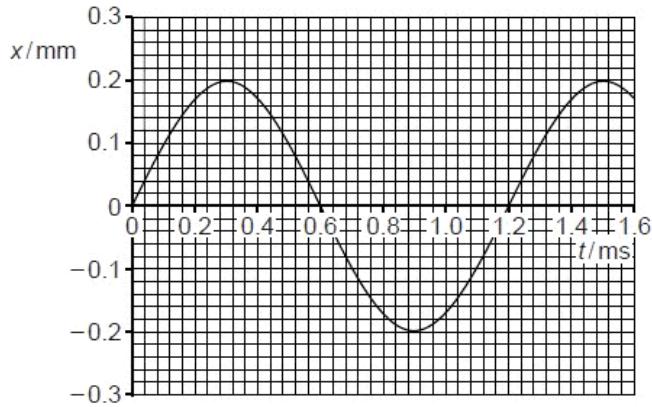

Fig. 4.1

- (a) Use Fig. 4.1 to determine, for these oscillations,

- (i) the amplitude,

amplitude = ..... mm [1]

- (ii) the frequency.

frequency = ..... Hz [2]

- (b) State two times at which

- (i) the speed of the cone is maximum,

time ..... ms and time ..... ms [1]

- (ii) the acceleration of the cone is maximum.

time ..... ms and time ..... ms [1]



(c) The effective mass of the cone is 2.5g.

Use your answers in (a) to determine the maximum kinetic energy of the cone.

F  
Exam  
U

kinetic energy = ..... J [3]

(d) The loudspeaker must be designed so that resonance of the cone is avoided.

(i) State what is meant by *resonance*.

.....  
.....  
..... [2]

(ii) State and briefly explain one other situation in which resonance should be avoided.

.....  
.....  
.....  
..... [2]

Q22.

- 3 The variation with displacement  $x$  of the acceleration  $a$  of the centre of the cone of a loudspeaker is shown in Fig. 3.1.

For  
Examiner  
Use

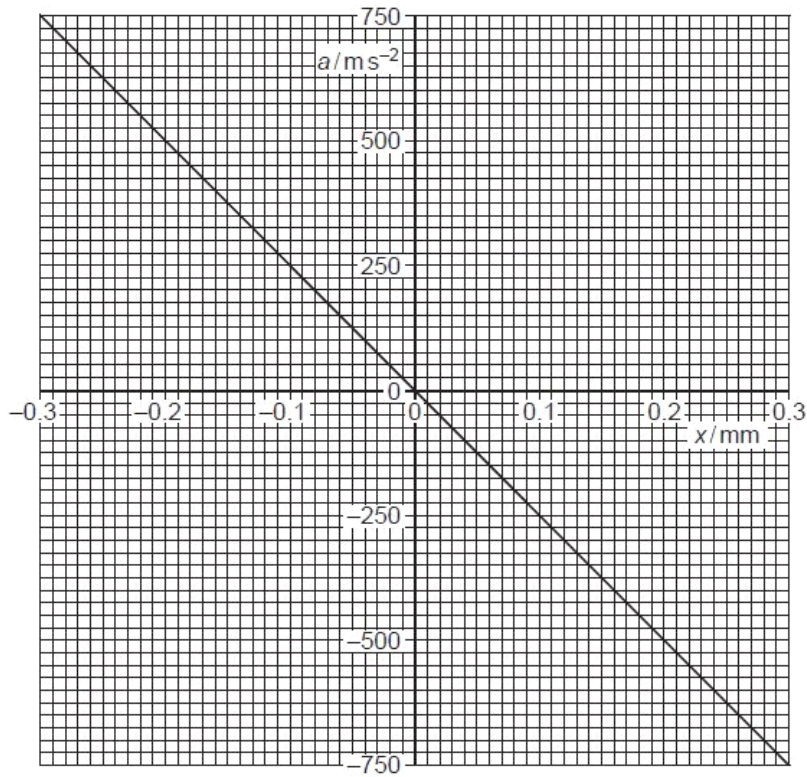

- (a) State the two features of Fig. 3.1 that show that the motion of the cone is simple harmonic.

1. ....

2. ....

[2]

- (b) Use data from Fig. 3.1 to determine the frequency, in hertz, of vibration of the cone.

frequency = ..... Hz [3]

- (c) The frequency of vibration of the cone is now reduced to one half of that calculated in (b).

For  
Examine  
Use

The amplitude of vibration remains unchanged.

On the axes of Fig. 3.1, draw a line to represent the variation with displacement  $x$  of the acceleration  $a$  of the centre of the loudspeaker cone.

[2]

### Q23.

- 3 A student sets up the apparatus illustrated in Fig. 3.1 in order to investigate the oscillations of a metal cube suspended on a spring.

For  
Examiner's  
Use

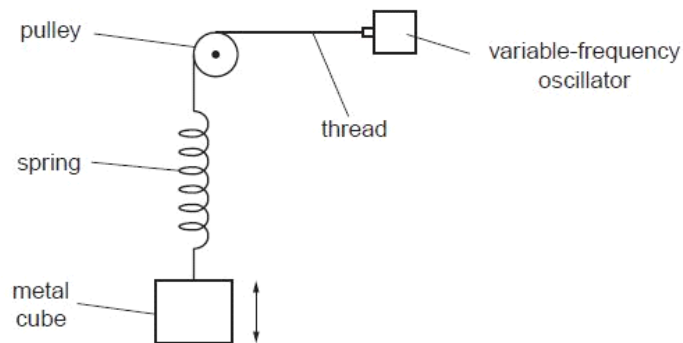
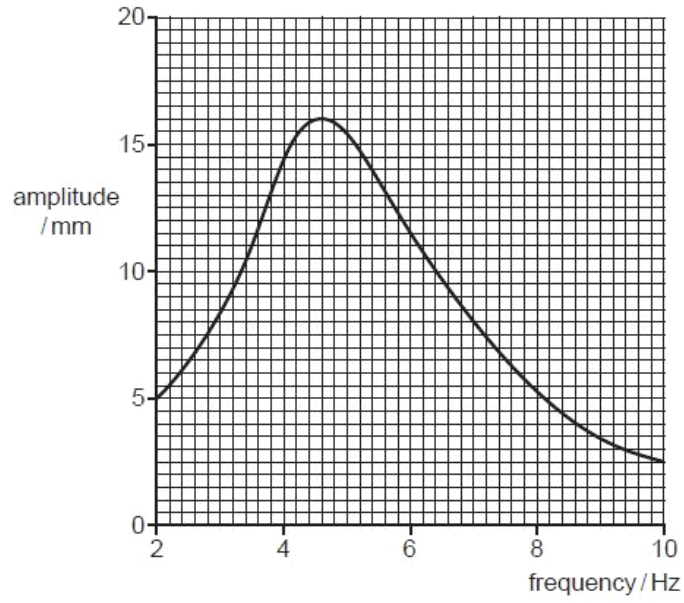

Fig. 3.1

The amplitude of the vibrations produced by the oscillator is constant.  
The variation with frequency of the amplitude of the oscillations of the metal cube is shown in Fig. 3.2.



**Fig. 3.2**

(a) (i) State the phenomenon illustrated in Fig. 3.2.

.....[1]

(ii) For the maximum amplitude of vibration, state the magnitudes of the amplitude and the frequency.

amplitude = ..... mm

frequency = ..... Hz

[1]

(b) The oscillations of the metal cube of mass 150g may be assumed to be simple harmonic.  
Use your answers in (a)(ii) to determine, for the metal cube,

(i) its maximum acceleration,

acceleration = .....  $\text{ms}^{-2}$  [3]

(ii) the maximum resultant force on the cube.

force = ..... N [2]

(c) Some very light feathers are attached to the top surface of the cube so that the feathers extend outwards, beyond the vertical sides of the cube.

The investigation is now repeated.

On Fig. 3.2, draw a line to show the new variation with frequency of the amplitude of vibration for frequencies between 2 Hz and 10 Hz. [2]

**Q24.**

- 3 A cylinder and piston, used in a car engine, are illustrated in Fig. 3.1.

For  
Examiner  
Use

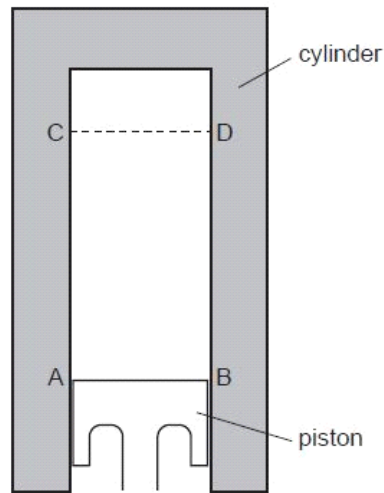

Fig. 3.1

The vertical motion of the piston in the cylinder is assumed to be simple harmonic. The top surface of the piston is at AB when it is at its lowest position; it is at CD when at its highest position, as marked in Fig. 3.1.

- (a) The displacement  $d$  of the piston may be represented by the equation

$$d = -4.0 \cos(220t)$$

where  $d$  is measured in centimetres.

- (i) State the distance between the lowest position AB and the highest position CD of the top surface of the piston.

distance = ..... cm [1]

- (ii) Determine the number of oscillations made per second by the piston.

For  
Examiner's  
Use

number = ..... [2]

- (iii) On Fig. 3.1, draw a line to represent the top surface of the piston in the position where the speed of the piston is maximum. [1]

- (iv) Calculate the maximum speed of the piston.

speed = .....  $\text{cm s}^{-1}$  [2]

- (b) The engine of a car has several cylinders. Three of these cylinders are shown in Fig. 3.2.

For  
Examiner's  
Use

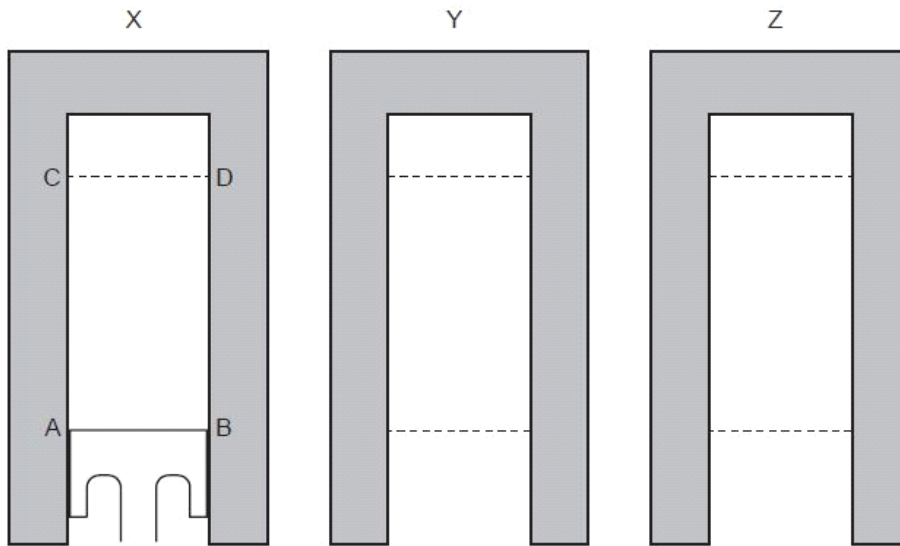

Fig. 3.2

X is the same cylinder and piston as in Fig. 3.1.

Y and Z are two further cylinders, with the lowest and the highest positions of the top surface of each piston indicated.

The pistons in the cylinders each have the same frequency of oscillation, but they are not in phase.

At a particular instant in time, the position of the top of the piston in cylinder X is as shown.

- (i) In cylinder Y, the oscillations of the piston lead those of the piston in cylinder X by a phase angle of  $120^\circ$  ( $\frac{2}{3}\pi$  rad).

Complete the diagram of cylinder Y, for this instant, by drawing

1. a line to show the top surface of the piston, [1]
2. an arrow to show the direction of movement of the piston. [1]



(ii) In cylinder Z, the oscillations of the piston lead those of the piston in cylinder X by a phase angle of  $240^\circ$  ( $\frac{4}{3}\pi$  rad).

For  
Examiner's  
Use

Complete the diagram of cylinder Z, for this instant, by drawing

1. a line to show the top surface of the piston, [1]

2. an arrow to show the direction of movement of the piston. [1]

(iii) For the piston in cylinder Y, calculate its speed for this instant.

speed = .....  $\text{cm s}^{-1}$  [2]

**Q25.**

3 A bar magnet is suspended from the free end of a helical spring, as illustrated in Fig. 3.1.

For  
Examiner's  
Use

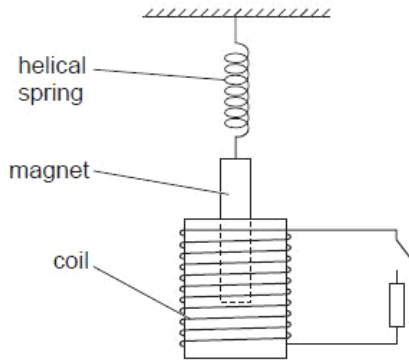

**Fig. 3.1**

One pole of the magnet is situated in a coil of wire. The coil is connected in series with a switch and a resistor. The switch is open.

The magnet is displaced vertically and then released. As the magnet passes through its rest position, a timer is started. The variation with time  $t$  of the vertical displacement  $y$  of the magnet from its rest position is shown in Fig. 3.2.

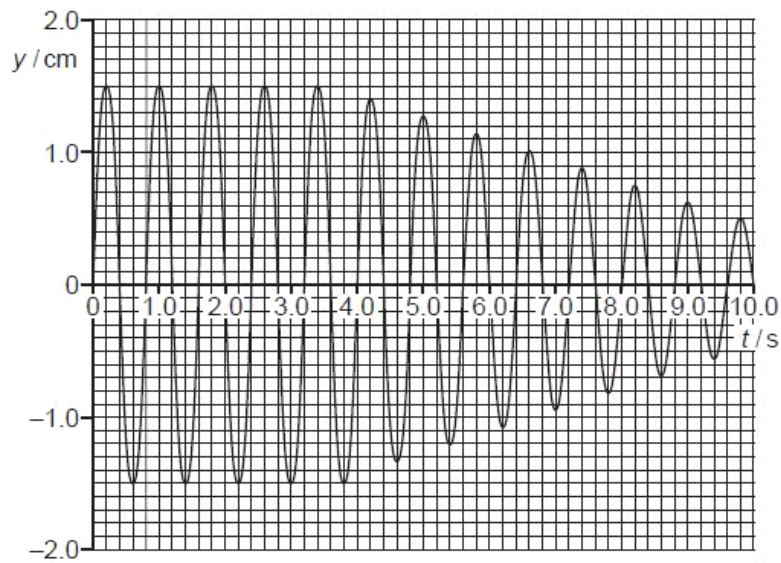

**Fig. 3.2**

At time  $t = 4.0$  s, the switch is closed.

**(a)** Use Fig. 3.2 to

- (i)** state the evidence for the magnet to be undergoing free oscillations during the period  $t = 0$  to  $t = 4.0$  s,

.....  
 .....[1]

- (ii)** state, with a reason, whether the damping after time  $t = 4.0$  s is light, critical or heavy,

.....  
 .....  
 .....[2]

- (iii)** determine the natural frequency of vibration of the magnet on the spring.

frequency = ..... Hz [2]

For  
Examiner's  
Use

**Q26.**

- 3 (a) Define *simple harmonic motion*.

.....  
.....  
..... [2]

For  
Examiner's  
Use

- (b) A horizontal plate is vibrating vertically, as shown in Fig. 3.1.

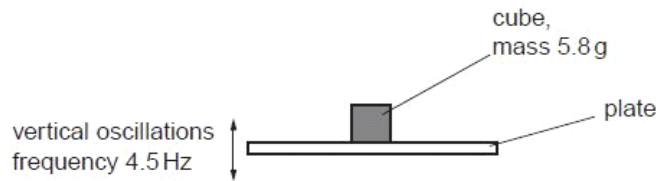

**Fig. 3.1**

The plate undergoes simple harmonic motion with a frequency of 4.5 Hz and amplitude 3.0 mm.  
A metal cube of mass 5.8 g rests on the plate.

Calculate, for the cube, the energy of oscillation.

energy = ..... J [3]

- (c) The amplitude of oscillation of the plate in (b) is gradually increased. The frequency remains constant.  
At one particular amplitude, the cube just loses contact momentarily with the plate.

- (i) State the position of the plate in its oscillation at the point when the cube loses contact.

.....  
.....  
..... [2]

(ii) Calculate this amplitude of oscillation.

For  
Exam  
Use

amplitude = ..... m [2]

**Q27.**

- 4 A ball is held between two fixed points A and B by means of two stretched springs, as shown in Fig. 4.1.

For  
Examiner's  
Use

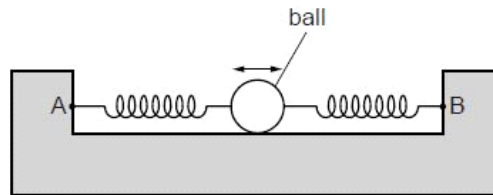

**Fig. 4.1**

The ball is free to oscillate horizontally along the line AB. During the oscillations, the springs remain stretched and do not exceed their limits of proportionality.

The variation of the acceleration  $a$  of the ball with its displacement  $x$  from its equilibrium position is shown in Fig. 4.2.

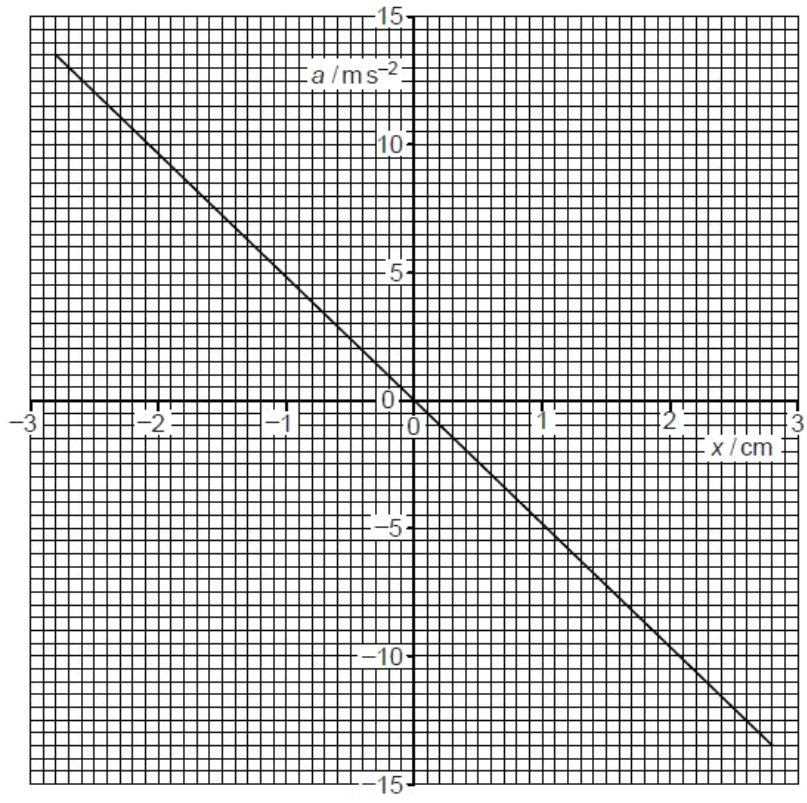

Fig. 4.2

(a) State and explain the features of Fig. 4.2 that indicate that the motion of the ball is simple harmonic.

.....  
.....  
.....  
.....  
..... [4]

(b) Use Fig. 4.2 to determine, for the oscillations of the ball,

(i) the amplitude,

amplitude = ..... cm [1]

(ii) the frequency.

frequency = ..... Hz [3]

(c) The arrangement in Fig. 4.1 is now rotated through  $90^\circ$  so that the line AB is vertical. The ball now oscillates in a vertical plane.

Suggest one reason why the oscillations may no longer be simple harmonic.

.....  
..... [1]

**Q28.**

- 2 A small frictionless trolley is attached to a fixed point A by means of a spring. A second spring is used to attach the trolley to a variable frequency oscillator, as shown in Fig. 2.1.

For  
Examiner's  
Use

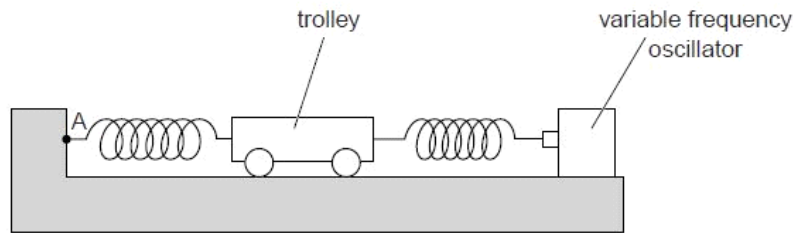

Fig. 2.1

Both springs remain extended within the limit of proportionality. Initially, the oscillator is switched off. The trolley is displaced horizontally along the line joining the two springs and is then released. The variation with time  $t$  of the velocity  $v$  of the trolley is shown in Fig. 2.2.

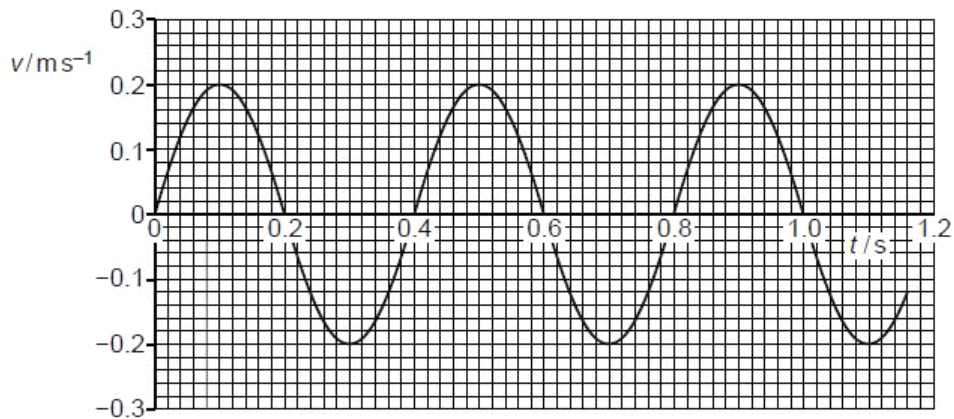

Fig. 2.2

- (a) (i) Using Fig. 2.2, state two different times at which

1. the displacement of the trolley is zero,

time = ..... s and time = ..... s [1]

2. the acceleration in one direction is maximum.

time = ..... s and time = ..... s [1]

(ii) Determine the frequency of oscillation of the trolley.

frequency = ..... Hz [2]

(iii) The variation with time of the displacement of the trolley is sinusoidal. The variation with time of the velocity of the trolley is also sinusoidal.

State the phase difference between the displacement and the velocity.

phase difference = ..... [1]

(b) The oscillator is now switched on. The amplitude of vibration of the oscillator is constant. The frequency  $f$  of vibration of the oscillator is varied. The trolley is forced to oscillate by means of vibrations of the oscillator. The variation with  $f$  of the amplitude  $a_0$  of the oscillations of the trolley is shown in Fig. 2.3.

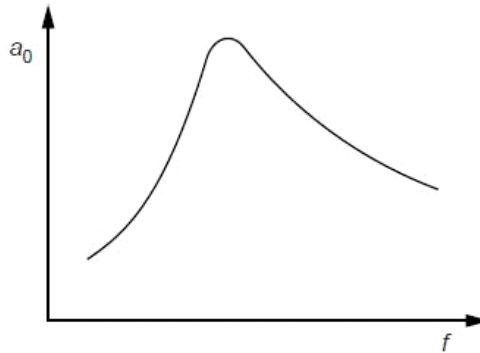

Fig. 2.3

By reference to your answer in (a), state the approximate frequency at which the amplitude is maximum.

frequency = ..... Hz [1]

(c) The amplitude of the oscillations in (b) may be reduced without changing significantly the frequency at which the amplitude is a maximum. State how this may be done and give a reason for your answer. You may draw on Fig. 2.1 if you wish.

.....  
.....  
.....  
.....  
..... [2]



**Q29.**

**3** A metal ball is suspended from a fixed point by means of a string, as illustrated in Fig. 3.1.

For  
Examine  
Use

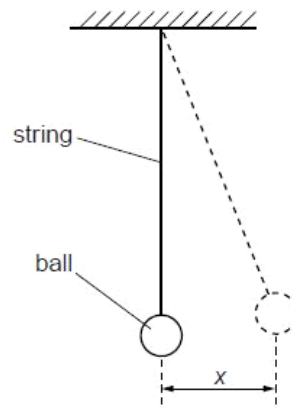

**Fig. 3.1**

The ball is given a small displacement and then released. The variation with time  $t$  of the displacement  $x$  of the ball is shown in Fig. 3.2.

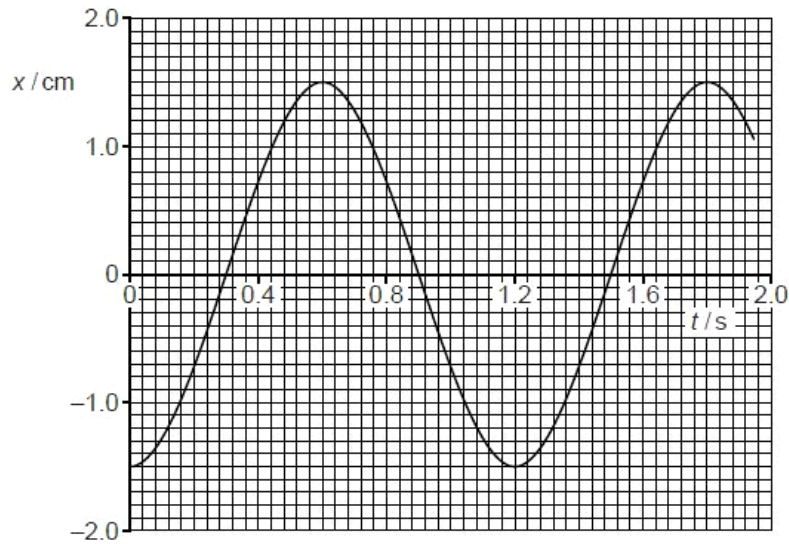

**Fig. 3.2**

**(a) (i)** State two times at which the speed of the ball is a maximum.

time = ..... s and time = ..... s [1]

(ii) Show that the maximum speed of the ball is approximately  $0.08 \text{ m s}^{-1}$ .

[2]

(b) The variation with displacement  $x$  of the potential energy  $E_p$  of the oscillations of the ball is shown in Fig. 3.3.

For  
Examiner's  
Use

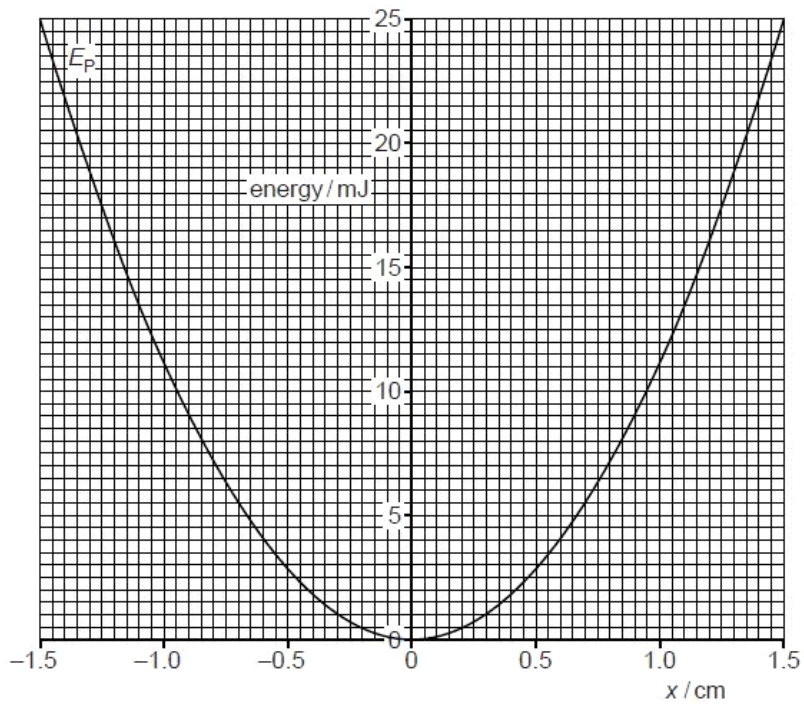

Fig. 3.3

- (i) On the axes of Fig. 3.3, sketch a graph to show the variation with displacement  $x$  of the kinetic energy of the ball. [2]
- (ii) The amplitude of the oscillations reduces over a long period of time. After many oscillations, the amplitude of the oscillations is 0.60 cm.

Use Fig. 3.3 to determine the total energy of the oscillations of the ball for oscillations of amplitude 0.60 cm. Explain your working.

energy = ..... J [2]

### Q30.

- 4 A student investigates the energy changes of a mass oscillating on a vertical spring, as shown in Fig. 4.1.

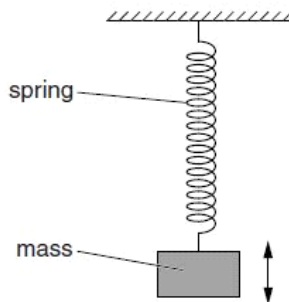

Fig. 4.1

The student draws a graph of the variation with displacement  $x$  of energy  $E$  of the oscillation, as shown in Fig. 4.2.

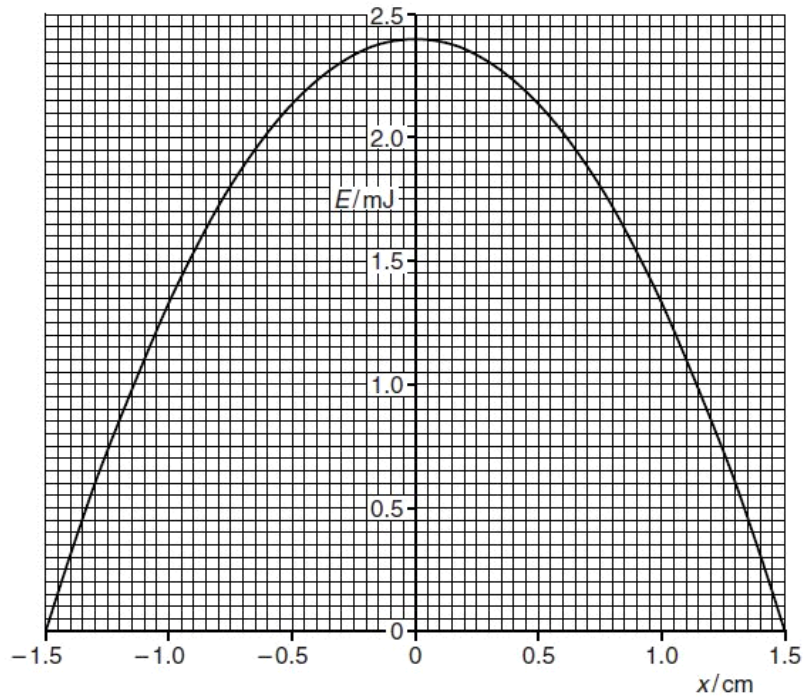

Fig. 4.2

- (a) State whether the energy  $E$  represents the total energy, the potential energy or the kinetic energy of the oscillations.

..... [1]

- (b) The student repeats the investigation but with a smaller amplitude. The maximum value of  $E$  is now found to be 1.8 mJ.

Use Fig. 4.2 to determine the change in the amplitude. Explain your working.

change in amplitude = ..... cm [3]

**Q31.**

- 4 (a) State what is meant by *simple harmonic motion*.

.....  
 .....  
 ..... [2]

- (b) A small ball rests at point P on a curved track of radius  $r$ , as shown in Fig. 4.1.

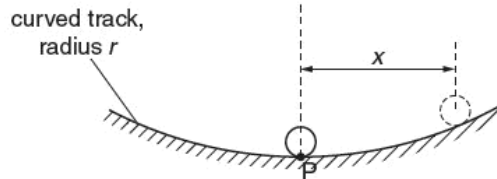

Fig. 4.1

The ball is moved a small distance to one side and is then released. The horizontal displacement  $x$  of the ball is related to its acceleration  $a$  towards P by the expression

$$a = -\frac{gx}{r}$$

where  $g$  is the acceleration of free fall.

- (i) Show that the ball undergoes simple harmonic motion.

.....  
 .....  
 .....  
 ..... [2]

- (ii) The radius  $r$  of curvature of the track is 28 cm.

Determine the time interval  $\tau$  between the ball passing point P and then returning to point P.

$\tau = \dots\dots\dots$  s [3]

(c) The variation with time  $t$  of the displacement  $x$  of the ball in (b) is shown in Fig. 4.2.

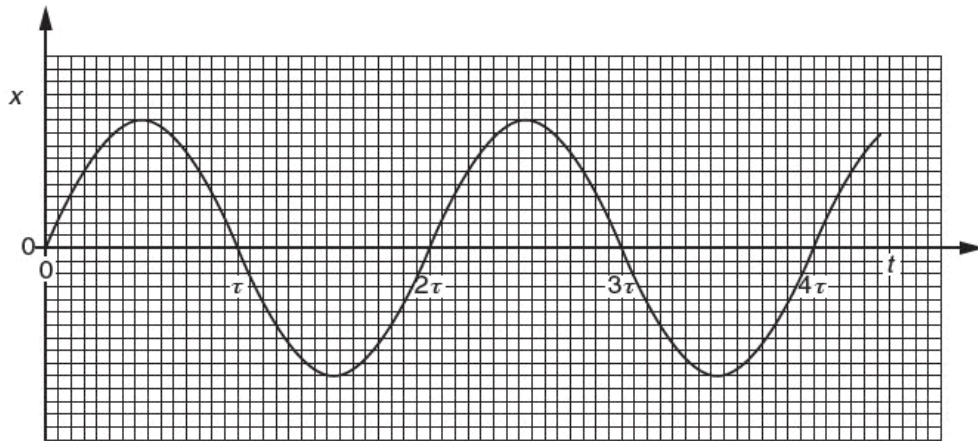

Fig. 4.2

Some moisture now forms on the track, causing the ball to come to rest after approximately 15 oscillations.

On the axes of Fig. 4.2, sketch the variation with time  $t$  of the displacement  $x$  of the ball for the first two periods after the moisture has formed. Assume the moisture forms at time  $t = 0$ .  
[3]

Q32.

- 1 A light spring is suspended from a fixed point. A bar magnet is attached to the end of the spring, as shown in Fig. 1.1.

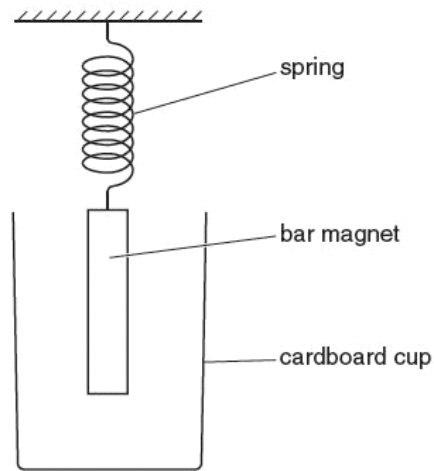

Fig. 1.1

In order to shield the magnet from draughts, a cardboard cup is placed around the magnet but does not touch it.

The magnet is displaced vertically and then released. The variation with time  $t$  of the vertical displacement  $y$  of the magnet is shown in Fig. 1.2.

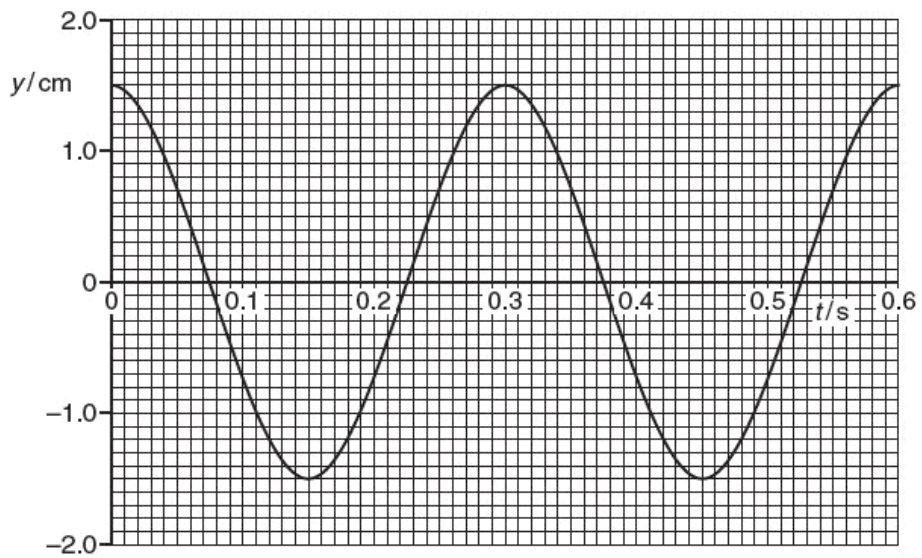

Fig. 1.2

The mass of the magnet is 130 g.

(a) For the oscillations of the magnet, use Fig. 1.2 to

(i) determine the angular frequency  $\omega$ ,

$$\omega = \dots\dots\dots \text{rads}^{-1} \quad [2]$$

(ii) show that the maximum kinetic energy of the oscillating magnet is 6.4 mJ.

[2]

(b) The cardboard cup is now replaced with a cup made of aluminium foil.

During 10 complete oscillations of the magnet, the amplitude of vibration is seen to decrease to 0.75 cm from that shown in Fig. 1.2. The change in angular frequency is negligible.

(i) Use Faraday's law of electromagnetic induction to explain why the amplitude of the oscillations decreases.

.....  
.....  
.....  
.....  
..... [3]



---

(ii) Show that the loss in energy of the oscillating magnet is 4.8 mJ.

[2]

(c) The mass of the aluminium cup in (b) is 6.2g. The specific heat capacity of aluminium is  $910 \text{ J kg}^{-1} \text{ K}^{-1}$ .  
The energy in (b)(ii) is transferred to the cup as thermal energy.  
Calculate the mean rise in temperature of the cup.

temperature rise = ..... K [2]

**Q33.**

4 (a) State what is meant by *simple harmonic motion*.

.....  
 .....  
 ..... [2]

(b) A trolley is attached to two extended springs, as shown in Fig. 4.1.

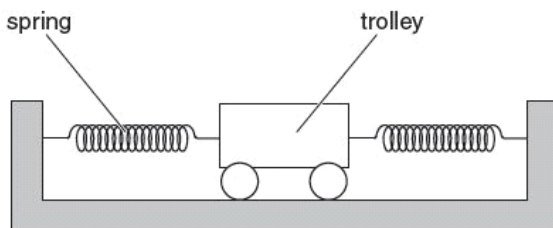

Fig. 4.1

The trolley is displaced along the line joining the two springs and is then released. At one point in the motion, a stopwatch is started. The variation with time  $t$  of the velocity  $v$  of the trolley is shown in Fig. 4.2.

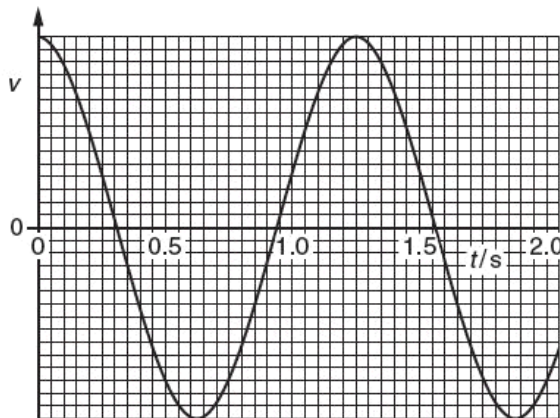

Fig. 4.2

The motion of the trolley is simple harmonic.

(i) State one time at which the trolley is moving through the equilibrium position and also state the next time that it moves through this position.

.....s and .....s [1]

(ii) The amplitude of vibration of the trolley is 3.2 cm.

Determine

1. the maximum speed  $v_0$  of the trolley,

$$v_0 = \dots\dots\dots \text{ cm s}^{-1} \quad [3]$$

2. the displacement of the trolley for a speed of  $\frac{1}{2}v_0$ .

$$\text{displacement} = \dots\dots\dots \text{ cm} \quad [2]$$

(c) Use your answers in (b) to sketch, on the axes of Fig. 4.3, a graph to show the variation with displacement  $x$  of the velocity  $v$  of the trolley.

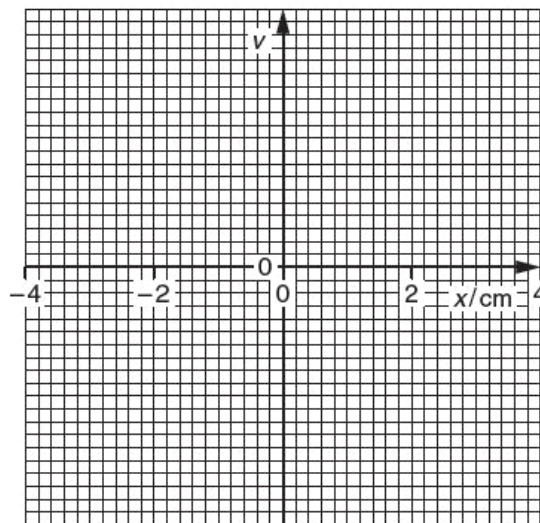

Fig. 4.3

[2]













